

# C25C

# C25

**20/25/30/32C**

IC-CUSHION      LPG  
4000 / 5000 / 6000 / 6500 lbs.  
(2000 / 2500 / 3000 / 3200 kg)

**20/25/30/35**

IC-PNEUMATIC      LPG/DIESEL  
4000 / 5000 / 6000 / 7000 lbs.  
(2000 / 2500 / 3000 / 3300 kg)

**GEN 2**



**CLARK**®

**THE FORKLIFT**



- The **operator compartment** is supported on rubber mounts, reducing the amount of engine noise and vibration transmitted to the operator. This ensures a more comfortable ride for the operator.



## Highly Maneuverable, Easily Serviceable, Broadly Flexible, Extremely Dependable

The GEN2 C20-series proudly adds to CLARK's unique history of building the best forklifts with evolutionary steps in **ergonomics, power, safety, durability, and performance**. These models, designed for distribution, manufacturing and warehousing of all types, are suited for the toughest applications.



# 95%

The large operator compartment's controls and seating are designed to maximize operator space and comfortably accommodate the ninety-five percentile in height range of the world's adult population.

- With available options including **full featured cab, various tire configurations, LED light technology, clean air package, custom tilts and rear work lights** (just to name a few) there is practically no application whose needs can't be met.

Smooth Control + Easy Operation =  
**Operator Confidence & Optimum Comfort**





- With four turns lock-to-lock the **hydrostatic power steering** provides the operator with excellent maneuverability and ease of control.



- Low, open foot steps with **traction plates** make entry/exit quick, easy and safe... from either side.



## Rugged Durability, High Performance, Extreme Environments, Demanding Applications

The GEN2 C20-series is designed to tackle any task placed in its path. The open-core, plate-fin radiator (standard on cushion models, optional on pneumatic models) provides **maximum cooling of the engine, transmission and axle in the harshest environments** and the most demanding applications.



# 10%

The Mitsubishi LPG engine produces only 10% of the allowable carbon monoxide by EPA emission standards.

- Nested upright rails provide positive rail interlock and a narrow “column” to **maximize the vision window**. The overhead guard safety bars run parallel to the operator’s line of sight resulting in a **clear, unobstructed view**.

Maximum Visibility + Minimum Fatigue =  
**Ultimate Safety & Product Integrity**

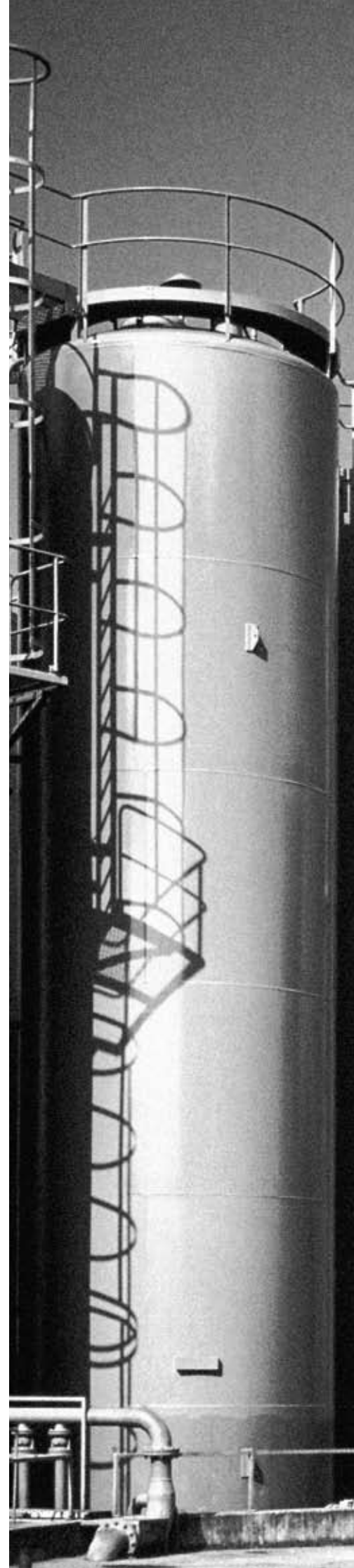



# C25 STANDARD FEATURES & BENEFITS



## PARKING BRAKE

### ■ Simple & Error Proof

- Foot-applied brake can be released by hand or foot.
- Transmission disengages when parking brake is set preventing driving against brakes.
- Horn will sound if brake not set after 3 seconds.

## HYDRAULIC SYSTEM

### ■ Maximum Horsepower

- Uses a load-sensing flow control valve for steering to reduce horsepower loss and heat buildup.

### ■ Optimum Performance Of Attachments

- The main hydraulic valve incorporates adjustable flow controls for tilt and auxiliary functions.

### ■ Sectional Design

- Allows for easy addition of extra functions and simplifies service.

### ■ Upright Mounted Load Lowering Valve

- Controlled lowering independent of engine speed.

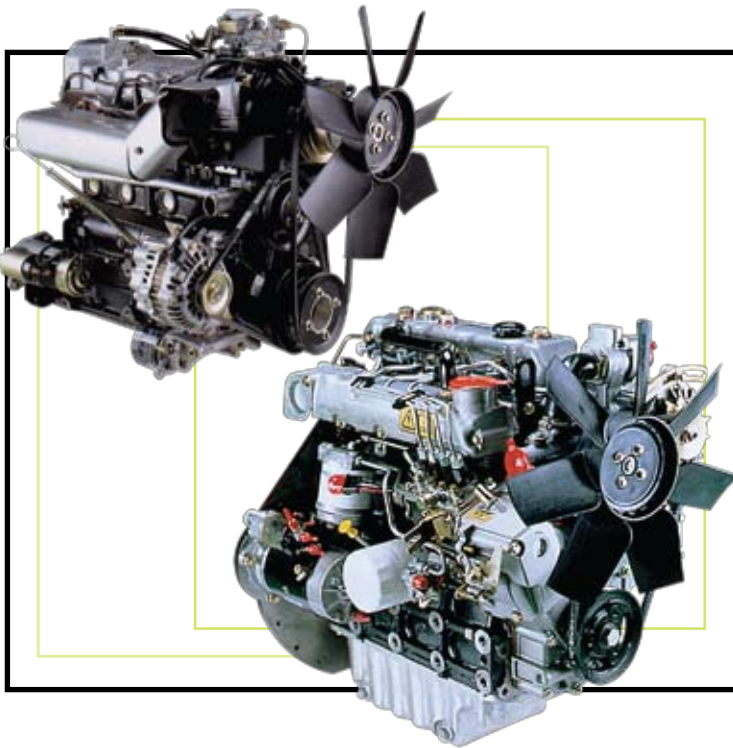

## THE POWER BEHIND THE PUNCH

### ■ Field-Proven Mitsubishi 4G64 LPG Engine

- The 4-cylinder, 48 HP, overhead cam engine with internal dynamic balancers provide a smooth and quiet operation.
- Hydraulic valve lifters and electronic ignition reduce maintenance requirements.

### ■ Recognized Worldwide Yanmar Diesel Engine

- Durable, easy to start, low-smoke, easy to service.
- High pressure direct-injection = better fuel economy.
- Vertical exhaust is standard equipment.

### ■ EPA Compliant

- Mitsubishi engine produces only 10% of the allowable carbon monoxide.
- Yanmar engine meets low-emission & low particulate requirements.

## Available Equipment

- Mirrors
- Sideshifters
- Strobe lights
- Backup alarm
- Rear work light
- Auxiliary valves
- Wide Drive Tires
- Turn signal lights
- Hose adaptations
- Combination lights
- Convenience console
- Bottler's tilt
- Tire Options
- Pre-cleaner
- Travel Speed Limit
- Hydraulic control options
- Air cleaner safety element
- U.L. Type LPS construction
- Suspension seat, vinyl and cloth
- Reduced height overhead guard
- Swing-Down LPG Tank Bracket
- Seat actuated engine shutdown

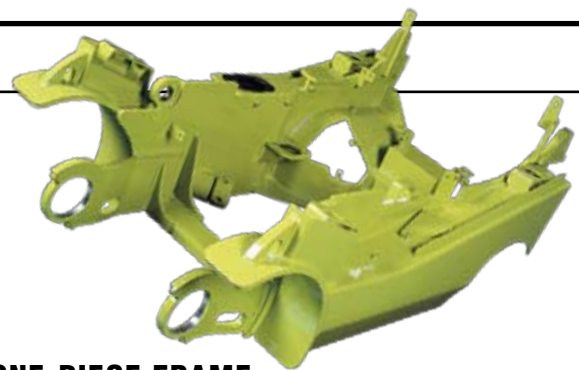

## ONE-PIECE FRAME

- Heavy duty, welded, and formed steel plate design protects from impact damage and extends the life of the truck.
- Integral hydraulic sump provides cooling for hydraulics

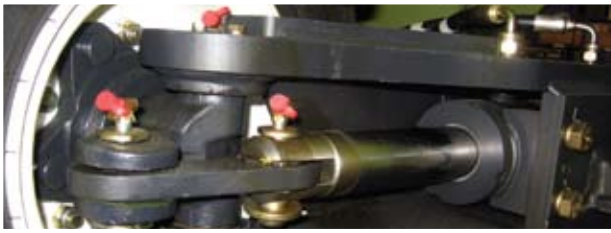

## STEERING AXLE

### ■ Rugged Design

- Linkage pivot pins have a “double shear” design to withstand impact without loosening or breaking.

### ■ Simple Axle Design

- Double-ended cylinder provides steering force.



## RUGGED UPRIGHT AND CARRIAGE

### ■ Maximum Visibility

- Nested I-Channel allows space for cylinders, hoses and chains.

### ■ Hydraulic Cushioning Valves

- Silent staging reduces shock & vibration.

### ■ Shimmable, Sealed & Canted Load Rollers

- Carriage has 6 load rollers.
- Maximize load distribution & reduce free play.



## DASH DISPLAY

### ■ Microprocessor

- Monitors the condition of truck systems as well as controlling their functions.
- Controls neutral starting and prevents cranking while the engine is running.

### ■ LCD Display

- Hourmeter and maintenance interval are displayed on the LCD screen.

### ■ LED Lights Indicate

- Transmission temperature • Engine oil pressure
- Alternator charge • Fuel system malfunction
- Park brake applied • Maintenance required • Seat belt

### ■ Push Switches

- Headlight and optional worklights are controlled with push switches.



## OPERATOR COMPARTMENT

### ■ Fully Adjustable Seat

- 2.4” vertical travel • 20° backrest adjustment range
- 6” fore / aft adjustment • Contoured for support
- Non-cinching, retractable seat belt

### ■ Thick Molded Floor Mat

- Reduces vibration and noise level.
- Improves operator comfort.

### ■ Minimal Arm Fatigue

- Electronic directional controls enable true fingertip operation.

### ■ Tilt Steering Column

### ■ Largest Operator Compartment In The Industry

# GENERAL DATA & STANDARD DIMENSIONS

## Upright Table

Maximum Fork Height in mm	Overall Height <sup>1</sup>		Tilt Spec <sup>2</sup> in mm	Standard B°/F°
	Lowered in	Free Lift mm		
<b>C20/25/30C Standard</b>				
83 2110	60.0	1525	4.3 110	6/10
105 2665	71.1	1806	4.3 110	8/10
117 2970	77.0	1955	4.3 110	8/10
• 130 3300	83.3	2115	4.3 110	10/8
146 3705	94.7	2405	4.3 110	10/8
152 3860	97.6	2480	4.3 110	10/8
164 4165	108.3	2750	4.3 110	5/6
172 4380	116.1	2950	4.3 110	5/6
182 4620	125.2	3180	4.3 110	5/6
203 5170	135.6	3445	4.3 110	5/3
<b>C32C Standard</b>				
• 127 3225	83.3	2120	4.5 115	8/10
144 3655	94.7	2415	4.5 115	10/8
<b>C20/25C Triple Stage<sup>3</sup></b>				
152 3860	71.1	1820	49.2 1252	5/6
170 4315	77.0	1955	55.2 1402	5/6
• 189 4800	83.3	2119	61.5 1562	5/6
205 5205	88.8	2256	67.0 1702	5/3
217 5510	94.7	2405	72.9 1852	5/3
226 5740	97.6	2479	75.9 1927	5/3
240 6095	103.9	2639	82.2 2087	5/3
251 6370	108.3	2750	86.5 2197	3/3
269 6830	116.1	2950	94.4 2397	3/3
288 7315	125.2	3180	103.4 2627	3/3
<b>C30C Triple Stage<sup>3</sup></b>				
152 3860	71.1	1820	46.9 1192	5/6
170 4315	77.0	1955	52.8 1342	5/6
• 189 4800	83.3	2119	59.1 1502	5/6
205 5205	88.8	2256	64.6 1642	5/3
217 5510	94.7	2405	70.6 1792	5/3
226 5740	97.6	2479	73.5 1867	5/3
240 6095	103.9	2639	79.8 2027	5/3
251 6370	108.3	2750	84.1 2137	3/3
269 6830	116.1	2950	92.0 2337	3/3
288 7315	125.2	3180	101.1 2567	3/3

## Upright Table (cont.)

Maximum Fork Height in mm	Overall Height <sup>1</sup>		Free Lift in mm	Standard Tilt Spec <sup>2</sup> B°/F°
	Lowered in	mm		
<b>C32C Triple Stage<sup>3</sup></b>				
164 4165	77.0	1960	51.0 1296	5/6
• 189 4800	85.4	2170	59.5 1511	5/6
199 5055	89.0	2265	62.8 1596	5/3
211 5355	95.0	2415	68.7 1746	5/3
<b>C20/25C Hi-Lo</b>				
115 2935	77	1956	55.2 1403	8/8
• 128 3250	83.3	2116	61.5 1563	8/8
139 3531	88.8	2256	67.0 1703	8/8
148 3760	94.7	2405	73.0 1853	8/8
154 3912	97.6	2479	75.9 1928	8/8
<b>C30C Hi-Lo</b>				
115 2935	77	1956	55.2 1403	8/8
• 128 3250	83.3	2116	61.5 1563	8/8
139 3531	88.8	2256	67.0 1703	8/8
148 3760	94.7	2405	73.0 1853	8/8
154 3912	97.6	2479	75.9 1928	8/8
<b>C20/25/30C Quad<sup>4</sup></b>				
216 5485	77	1956	52.0 1320	3/0
• 240 6096	83	2108	58.0 1473	3/0
258 6553	89	2260	64.0 1625	3/0
276 7010	95	2413	70.0 1778	3/0
294 7465	101	2565	76.0 1930	3/0
312 7925	107	2718	82.0 2082	3/0

## Grade Clearance

Model	A%	B%
C20/25/30/32C	39.4	16.3

\* Indicates Common Preferred Spec

- 1 For overall height raised with load backrest, add 48 in. (1220 mm) to maximum fork height.
- 2 Standard tilt shown. Contact Clark representative for information on optional tilt.
- 3 Wide stance wheel (standard tire) is provided with all Quad uprights and all triple stage uprights over 240 in. (6095 mm) Maximum Fork Height – overall truck width is 48.8 in. (1240 mm) on C20/25C and 50.8 in. (1290 mm) on the C30/32C.
- 4 Freelif dimensions shown are without load backrest.

Other uprights available, contact a Clark representative.

## Notes

Production engines and driveline components may vary in output and/or efficiency by  $\pm 5\%$ . The performance shown represents nominal values which may be obtained under typical operating conditions of a machine.

## ANSI/ITSDF and Insurance Classification

Standard truck meets all applicable mandatory requirements of Part III-ANSI/ITSDF B56.1 Safety Standard for Powered Industrial Trucks and Underwriters Laboratories requirements as to fire hazard only for D and LP classifications. For further information contact a Clark representative.

Users should be aware of, and adhere to, applicable codes and regulations regarding operator training, use, operation and maintenance of powered industrial trucks, including:

- ANSI/ITSDF B56.1
- NFPA 505, fire safety standard for powered industrial trucks - type designations, areas of use, maintenance and operation.
- Occupational Safety and Health Administration (OSHA) regulations that may apply.

Contact your authorized CLARK forklift truck dealer for further information including operator training programs and auxiliary visual and audible warning systems, fire extinguishers, etc., as available for specific user applications and requirements.

Specifications, equipment, technical data, photos and illustrations are based on information at time of printing and are subject to change without notice. Some products may be shown with optional equipment.

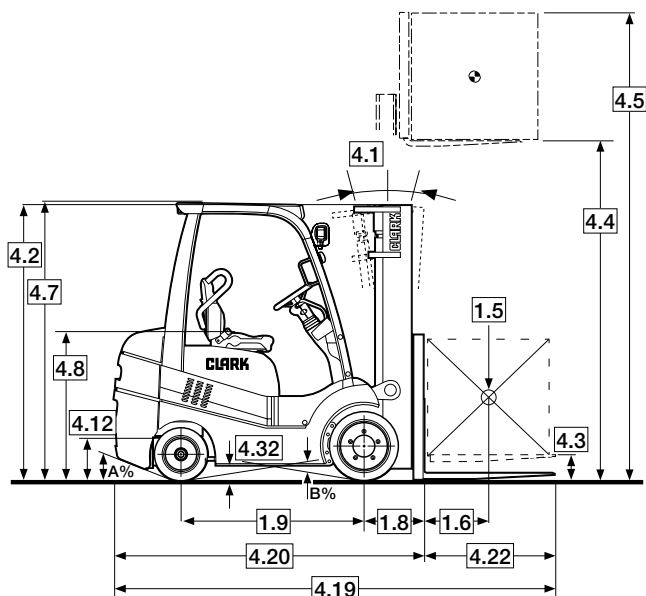
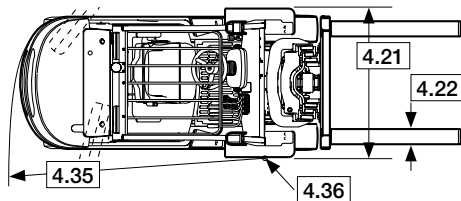

For corresponding data see Specification Chart



## Upright Table

	Maximum Fork Height		Overall Height <sup>1</sup> Lowered		Free Lift		Standard Tilt Spec <sup>2</sup> B°/F°
	in	mm	in	mm	in	mm	
<b>C20/25 Standard</b>							
83	2110	62.0	1575	4.1	105	6/10	
105	2665	73.0	1854	4.1	105	8/10	
117	2970	78.9	2004	4.1	105	8/10	
• 130	3300	85.2	2164	4.1	105	10/8	
146	3705	96.7	2456	4.1	105	10/8	
152	3860	99.6	2529	4.1	105	10/8	
164	4165	110.2	2799	4.1	105	5/6	
172	4380	118.1	2999	4.1	105	5/6	
182	4620	127.2	3230	4.1	105	5/6	
203	5170	137.6	3495	4.1	105	5/3	
<b>C30 Standard</b>							
83	2110	62.6	1590	4.3	110	6/10	
105	2665	73.6	1869	4.3	110	8/10	
117	2970	79.5	2019	4.3	110	8/10	
• 130	3300	85.8	2179	4.3	110	10/8	
146	3705	97.2	2468	4.3	110	10/8	
152	3860	100.2	2545	4.3	110	10/8	
164	4165	110.8	2814	4.3	110	5/6	
172	4380	118.7	3014	4.3	110	5/6	
182	4620	127.8	3246	4.3	110	5/6	
203	5170	138.2	3510	4.3	110	5/3	
<b>C35 Standard</b>							
152	3860	71.1	1820	49.2	1252	5/6	
170	4315	77.0	1955	55.2	1402	5/6	
• 189	4800	83.3	2119	61.5	1562	5/6	
205	5205	88.8	2256	67.0	1702	5/3	
217	5510	94.7	2405	72.9	1852	5/3	
226	5740	97.6	2479	75.9	1927	5/3	
240	6095	103.9	2639	82.2	2087	5/3	
251	6370	108.3	2750	86.5	2197	3/3	
269	6830	116.1	2950	94.4	2397	3/3	
288	7315	125.2	3180	103.4	2627	3/3	
<b>C20/25 Triple Stage<sup>3</sup></b>							
152	3860	73.0	1854	47.3	1201	5/6	
170	4315	78.9	2004	53.2	1351	5/6	
• 189	4800	85.2	2164	59.5	1511	5/6	
205	5205	90.7	2303	64.9	1648	5/3	
217	5510	96.7	2456	70.9	1800	5/3	
226	5740	99.6	2529	73.8	1875	5/3	
240	6095	105.9	2689	80.1	2035	5/3	
251	6370	110.2	2799	84.5	2135	3/3	
269	6830	118.1	2999	92.3	2344	3/3	
288	7315	127.2	3230	101.4	2576	3/3	
<b>C30 Triple Stage<sup>3</sup></b>							
152	3860	73.6	1869	45.5	1156	5/6	
170	4315	79.5	2019	51.4	1306	5/6	
• 189	4800	85.8	2179	57.7	1466	5/6	
205	5205	91.3	2319	63.2	1605	5/3	
217	5510	97.2	2468	69.1	1755	5/3	
226	5740	100.2	2545	72.0	1829	5/3	
240	6095	106.5	2705	78.3	1989	5/3	
251	6370	110.8	2814	82.7	2100	3/3	
269	6830	118.7	3014	90.5	2299	3/3	
288	7315	127.8	3246	99.6	2530	3/3	
<b>C35 Triple Stage<sup>3</sup></b>							
146	3680	74	1890	44	1120	5/6	
163	4140	80	2040	50	1270	5/6	
• 182	4620	87	2200	57	1450	5/6	
198	5030	92	2340	62	1575	5/6	
210	5340	98	2490	68	1725	5/3	
219	5560	101	2565	71	1805	5/3	
233	5920	107	2725	77	1955	5/3	
243	6190	112	2835	82	2085	5/3	
262	6650	119	3035	89	2260	3/3	
281	7135	129	3265	99	2515	3/3	
<b>C20/25 Hi-Lo</b>							
116	2945	78.9	2004	54.4	1381	8/8	
• 128	3250	85.2	2164	60.7	1541	8/8	
139	3531	90.7	2303	66.2	1681	8/8	
148	3760	96.7	2456	72.1	1831	8/8	
154	3912	99.6	2529	75.1	1907	8/8	
<b>C30 Hi-Lo</b>							
116	2945	79.5	2019	52.4	1331	8/8	
• 128	3250	85.8	2179	58.7	1491	8/8	
139	3531	91.3	2319	64.2	1631	8/8	
148	3760	97.2	2468	70.1	1781	8/8	
154	3912	100.2	2545	73.1	1857	8/8	

## Upright Table (cont.)

	Maximum Fork Height		Overall Height <sup>1</sup> Lowered		Free Lift		Standard Tilt Spec <sup>2</sup> B°/F°
	in	mm	in	mm	in	mm	
<b>C20/25/30 Quad<sup>3</sup></b>							
216	5485	79	2006	53	1346	3/0	
• 240	6096	85	2159	59	1499	3/0	
258	6553	91	2311	65	1651	3/0	
276	7010	97	2463	71	1803	3/0	
294	7465	103	2616	77	1955	3/0	
312	7925	109	2769	83	2108	3/0	
<b>Grade Clearance</b>							A%
<b>Model</b>							<b>A%</b>
C20/25							57.7
C30							57.7
C35							30.0
							<b>B%</b>
							23.2
							22.9
							25.4

- Indicates preferred common specification.
- 1 For overall height raised with load backrest, add 48 in. (1220 mm) to maximum fork height.
- 2 Standard tilt shown. Contact Clark representative for information on optional tilt.
- 3 A dual stage master cylinder assures smooth braking and reduced pedal effort with short pedal stroke. For single drive request special quote. Quads require Class II carriages, forks and load backrests.
- 4 Freelif dimensions shown are without load backrest.

Other uprights available, contact a Clark representative.

### Notes

Production engines and driveline components may vary in output and/or efficiency by ±5%. The performance shown represents nominal values which may be obtained under typical operating conditions of a machine.

### ANSI/ITSDF and Insurance Classification

Standard truck meets all applicable mandatory requirements of Part III-ANSI/ITSDF B56.1 Safety Standard for Powered Industrial Trucks and Underwriters Laboratories requirements as to fire hazard only for D and LP classifications. For further information contact a Clark representative.

Users should be aware of, and adhere to, applicable codes and regulations regarding operator training, use, operation and maintenance of powered industrial trucks, including:

- ANSI/ITSDF B56.1
- NFPA 505, fire safety standard for powered industrial trucks - type designations, areas of use, maintenance and operation.
- Occupational Safety and Health Administration (OSHA) regulations that may apply.

Contact your authorized CLARK forklift truck dealer for further information including operator training programs and auxiliary visual and audible warning systems, fire extinguishers, etc., as available for specific user applications and requirements.

Specifications, equipment, technical data, photos and illustrations are based on information at time of printing and are subject to change without notice. Some products may be shown with optional equipment.

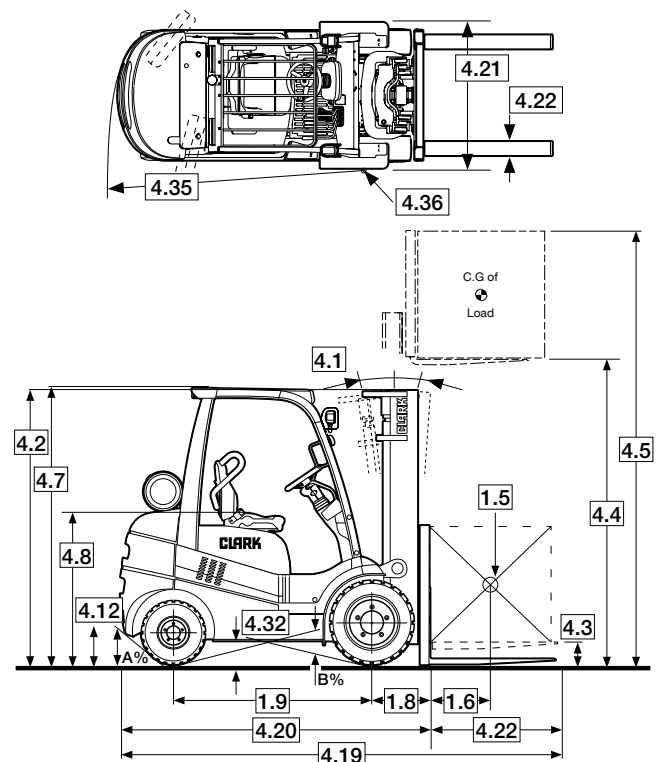

For corresponding data see Specification Chart



# STANDARD SPECIFICATIONS C20/25/30/32C

Specifications	1.1	Manufacturer		Clark	Clark	Clark
	1.2	Manufacturer's Designation		C20CL	C25CL	C30CL
	1.3	Drive unit Diesel, L.P. Gas		LPG	LPG	LPG
	1.4	Operator type stand on / driver seated		Rider counterbalanced	Rider counterbalanced	Rider counterbalanced
	1.5	Load capacity / rated load	lbs(kg)	4000 (2000)	5000 (2500)	6000 (3000)
	1.6	Load center distance	in(mm)	24 (500)	24 (500)	24 (500)
	1.8	Load center distance, center of drive axle to fork face	in(mm)	STD 15.4 (391)   TSU 16.7 (424)	STD 15.4 (391)   TSU 16.7 (424)	STD 15.6 (396)   TSU 16.9 (429)
	1.9	Wheelbase	in(mm)	55.1 / (1400)	55.1 / (1400)	55.1 (1400)
	Weight	2.1	Service weight	lbs(kg)	8,137 (3691)	8955 (4062)
2.2		Axle loading, loaded front / rear	lbs(kg)	11,122 / 1424 (5045 / 646)	12,712 / 1755 (5766 / 796)	14,358 / 2154 (6513 / 977)
2.3		Axle loading, unloaded front / rear	lbs(kg)	3796 / 4341 (1722 / 1969)	3554 / 5401 (1612 / 2450)	3369 / 6530 (1528 / 2962)
Tires	3.1	Tire type, P = pneumatic, SE = solid pneu, C = cushion		Cushion	Cushion	Cushion
	3.2	Tire size, front	in	21x7x15	21x7x15	21x8x15
	3.3	Tire size, rear	in	16x5x10.5	16x5x10.5	16x6x10.5
	3.5	Wheels, number front / rear (x = drive wheels)		2 x / 2	2 x / 2	2 x / 2
	3.6	Tread, front	in(mm)	34.7 (882)	34.7 (882)	35.7 (908)
	3.7	Tread, rear		35.2 (895)	35.2 (895)	36.2 (920)
Dimensions	4.1	Tilt of upright / fork carriage, back / forward, a / b	degrees	5B / 6F	5B / 6F	5B / 6F
	4.2	Height, upright lowered	in(mm)	STD 83.3 (2116)   TSU 83.3 (2116)	STD 83.3 (2116)   TSU 83.3 (2116)	STD 83.3 (2116)   TSU 83.3 (2116)
	4.3	Freelift	in(mm)	STD 4.3 (109)   TSU 61.5 (1562)	STD 4.3 (109)   TSU 61.5 (1562)	STD 4.3 (109)   TSU 61.5 (1562)
	4.4	Lift height	in(mm)	STD 130 (3302)   TSU 189 (4800)	STD 130 (3302)   TSU 189 (4800)	STD 130 (3302)   TSU 189 (4800)
	4.5	Height, upright extended	in(mm)	STD 178 (4521)   TSU 237 (6020)	STD 178 (4521)   TSU 237 (6020)	STD 178 (4521)   TSU 237 (6020)
	4.7	Height overhead guard	in(mm)	82.8 (2105)	82.8 (2105)	82.8 (2105)
	4.8	Seat height		45.9 (1165)	45.9 (1165)	45.9 (1165)
	4.12	Coupling height	in(mm)	11.0 (279)	11.0 (279)	11.0 (279)
	4.19	Overall length	in(mm)	STD 129.2 (3282)   TSU 130.5 (3315)	STD 131.6 (3343)   TSU 132.9 (3375)	STD 133.6 (3393)   TSU 134.9 (3426)
	4.20	Length to face of forks	in(mm)	STD 87.2 (2214)   TSU 88.5 (2248)	STD 89.6 (2276)   TSU 90.9 (2310)	STD 91.6 (2327)   TSU 92.9 (2359)
	4.21	Width	in(mm)	42.5 (1080)	42.5 (1080)	43.7 (1110)
	4.22	Fork dimensions	in(mm)	1.75x4x42 (45x100x1070)	1.75x4x42 (45x100x1070)	1.75x4.8x42 (45x122x1070)
	4.23	Fork carriage		Hook Type	Hook Type	Hook Type
	4.24	Fork carriage width	in(mm)	37.0 (940)	37.0 (940)	41.0 (1041)
	4.31	Ground clearance minimum, loaded	in(mm)	3.35 (85)	3.35 (85)	3.35 (85)
	4.32	Ground clearance center of wheelbase	in(mm)	4.3 (110)	4.3 (110)	4.3 (110)
4.34	Right Angle Stack (add load length and clearance)	in(mm)	STD 93.2 (2367)   TSU 94.5 (2399)	STD 95.3 (2426)   TSU 96.8 (2459)	STD 97.9 (2487)   TSU 99.2 (2519)	
4.35	Outside turning radius	in(mm)	77.8 (1975)	80.1 (2035)	82.3 (2090)	
4.36	Inside turning radius	in(mm)	3.53 (89.6)	3.53 (89.6)	3.00 (76.4)	
Performance	5.1	Travel speed loaded / unloaded	mph(kph)	10.4 / 10.4 (16.8 / 16.8)	10.4 / 10.4 (16.8 / 16.8)	10.3 / 10.3 (16.7 / 16.7)
	5.2	Lift speed loaded / unloaded	fpm(ms)	STD 106/124 (.54/.63)   TSU 102/126 (.52/.61)	STD 104/124 (.53/.63)   TSU 100/120 (.51/.61)	STD 102/124 (.52/.63)   TSU 98/120 (.50/.61)
	5.3	Lowering speed loaded / unloaded	fpm(ms)	STD 89/89 (.45/.45)   TSU 85/85 (.43/.43)	STD 89/89 (.45/.45)   TSU 85/85 (.43/.43)	STD 89/89 (.45/.45)   TSU 85/85 (.43/.43)
	5.6	Max. drawbar pull loaded	lbs(N)	4850 / 21570	4850 / 21570	4850 / 21570
	5.8	Max. gradeability loaded / unloaded	%	39.5 / 26.2	33.2 / 21.7	28.3 / 18.4
	5.10	Service brake		Drum	Drum	Drum
Drive Line	7.1	Manufacturer / Type		Mitsubishi / 4G64	Mitsubishi / 4G64	Mitsubishi / 4G64
	7.2	Rated output per SAE J1349	HP/kW @ rpm	47.5 / 35.4 @ 2250	47.5 / 35.4 @ 2250	47.5 / 35.4 @ 2250
	7.3	Rated speed	rpm	2650	2650	2650
	7.4	No. of cylinders / displacement	cu. in.-Liters	4 / 143 - 2.4	4 / 143 - 2.4	4 / 143 - 2.4
	8.2	Operating pressure for attachments	psi/bar	Adjustable	Adjustable	Adjustable
	8.4	Sound level, driver's ear	dB(A)	78	78	78



Clark	Clark	Clark	Clark	Clark
C32CL	C20L	C25L	C35L	C30L
LPG	LPG	LPG	LPG	LPG
Rider counterbalanced	Rider counterbalanced	Rider counterbalanced	Rider counterbalanced	Rider counterbalanced
6500 (3200)	4000 (2000)	5000 (2500)	7000 (3300)	6000 (3000)
24 (500)	24 (500)	24 (500)	24 (500)	24 (500)
STD 16.2 (411)   TSU 17.5 (445)	STD/TSU 17.9 (455)	STD/TSU 17.9 (455)	STD/TSU 18.7 (475)	STD/TSU 18.8 (477)
55.1 (1400)	63.8 (1620)	63.8 (1620)	66.9 (1700)	66.9 (1700)
10,254 (4651)	8088 (3669)	8838 (4009)	10300 (4672)	9786 (4439)
15,064 / 2244 (6833 / 1018)	10,885 / 1203 (4937 / 546)	12,386 / 1452 (5618 / 659)	15,138 / 2162 (6881 / 983)	14,213 / 1573 (6447 / 713)
3318 / 6936 (1505 / 3146)	4258 / 3830 (1931 / 1737)	4101 / 4737 (1860 / 2149)	3671 / 6629 (1665 / 3007)	4271 / 5515 (1937 / 2502)
Cushion	Pneumatic	Pneumatic	Pneumatic	Pneumatic
21x9x15	7.00x12 - 14PR	7.00x12 - 14PR	250x15-18PR	8.15x15 - 14PR
16x6x10.5	6.00x9 - 10PR	6.00x9 - 10PR	6.50x10-12PR	6.50x10 - 12PR
2 x / 2	2 x / 2	2 x / 2	2 x / 2	2 x / 2
36.7 (932)	39.1 (994)	39.1 (994)	41.3 (1050)	40.5 (1028)
36.2 (920)	35.6 (904)	35.6 (904)	35.9 (912)	35.9 (912)
5B / 6F	5B / 6F	5B / 6F	5B/6F	5B / 6F
STD 83.3 (2116)   TSU 85.4 (2169)	STD 85.2 (2165)   TSU 85.2 (2165)	STD 85.2 (2165)   TSU 85.2 (2165)	STD 87 (2200)   TSU 87.0 (2200)	STD 85.8 (2180)   TSU 85.8 (2180)
STD 4.5 (114)   TSU 59.5 (1511)	STD 4.1 (104)   TSU 59.2 (1511)	STD 4.1 (104)   TSU 59.2 (1511)	STD 4.5 (114)   TSU 57.0 (1448)	STD 4.3 (109)   TSU 57.7 (1466)
STD 127 (3225)   TSU 189 (4800)	STD 130 (3302)   TSU 189 (4800)	STD 130 (3302)   TSU 189 (4800)	STD 125 (3175)   TSU 182 (4620)	STD 130 (3302)   TSU 189 (4800)
STD 175 (4445)   TSU 237 (6020)	STD 178 (4521)   TSU 237 (6020)	STD 178 (4521)   TSU 237 (6020)	STD 173 (4394)   TSU 230 (5842)	STD 178 (4521)   TSU 237 (6020)
82.8 (2105)	85.2 (2165)	85.2 (2165)	86.4(2195)	85.8 (2180)
45.9 (1165)	44.7 (1135)	44.7 (1135)	45.7 (1161)	45.3 (1151)
11.0 (279)	16.0 (406)	16.0 (406)	16.0 (406)	16.0 (406)
STD 135.9 (3452)   TSU 137.2 (3485)	STD/TSU 140.3 (3564)	STD/TSU 142.7 (3625)	STD/TSU 151.0 (3835)	STD/TSU 147.0 (3734)
STD 93.9 (2385)   TSU 95.2 (2417)	STD/TSU 98.3 (2496)	STD/TSU 100.7 (2558)	STD/TSU 109.0 (2770)	STD/TSU 105.0 (2668)
45.4 (1154)	48.2 (1225)	48.2 (1225)	51.8 (1315)	48.7 (1237)
2x4.8x42 (50x122x1070)	1.75x4x42 (45x100x1070)	1.75x4x42 (45x100x1070)	2.0x4.8x42 (50x122x1070)	1.75x4.8x42 (45x122x1070)
Hook Type	Hook Type	Hook Type	Hook Type	Hook Type
41.0 (1041)	41.0 (1041)	41.0 (1041)	45.0 (1143)	41.0 (1041)
3.35 (85)	5.3 (135)	5.3 (135)	6.5 (165)	5.9 (150)
4.3 (110)	6.1 (155)	6.1 (155)	6.5 (165)	6.5 (165)
STD 100.1 (2543)   TSU 101.4 (2575)	STD/TSU 106.3 (2700)	STD/TSU 108.5 (2755)	STD/TSU 116.3 (2955)	STD/TSU 113.5 (2882)
83.9 (2130)	88.4 (2245)	90.6 (2300)	97.6 (2480)	94.7 (2405)
2.15 (54.7)	11.5 (291)	11.5 (291)	11.3 (287)	11.3 (287)
10.2 / 10.2 (16.5 / 16.5)	12.5/12.5 (20.1/20.1)	12.4/12.4 (20.0/20.0)	12.6/13.3 (20.3/21.4)	12.5/13.2 (20.1/21.2)
STD 102/124 (.52/.63)   TSU 96/120 (.49/.61)	STD 106/124 (.54/.63)   TSU 102/126 (.52/.61)	STD 104/124 (.53/.63)   TSU 100/120 (.51/.61)	STD 83/102 (.42/.52)   TSU 79/98 (.40/.50)	STD 102/124 (.52/.63)   TSU 98/120 (.50/.61)
STD 89/89 (.45/.45)   TSU 85/85 (.43/.43)	STD 89/89 (.45/.45)   TSU 85/85 (.43/.43)	STD 89/89 (.45/.45)   TSU 85/85 (.43/.43)	STD 89/89 (.45/.45)   TSU 85/85 (.43/.43)	STD 89/89 (.45/.45)   TSU 85/85 (.43/.43)
4850 / 21570	4125 / 18350	4125 / 18350	4675 / 20795	4700 / 20906
26.8 / 17.4	32.6 / 23.3	28.2 / 20.3	19.0 / 16.4	29.4 / 19.2
Drum	Drum	Drum	Drum	Drum
Mitsubishi / 4G64	Mitsubishi / 4G64	Mitsubishi / 4G64	Mitsubishi / 4G64	Mitsubishi / 4G64
47.5 / 35.4 @ 2250	47.5 / 35.4 @ 2250	47.5 / 35.4 @ 2250	47.5 / 35.4 @ 2250	47.5 / 35.4 @ 2250
2650	2650	2650	2650	2650
4 / 143 - 2.4	4 / 143 - 2.4	4 / 143 - 2.4	4 / 143 - 2.4	4 / 143 - 2.4
Adjustable	Adjustable	Adjustable	Adjustable	Adjustable
78	78	78	78	78



# C20/25/30/35

Clark	Clark	Clark	Clark
C20D	C25D	C30D	C35D
Diesel	Diesel	Diesel	Diesel
Rider counterbalanced	Rider counterbalanced	Rider counterbalanced	Rider counterbalanced
4000 (2000)	5000 (2500)	6000 (3000)	7000 (3300)
24 (500)	24 (500)	24 (500)	24 (500)
STD/TSU 17.9 (455)	STD/TSU 17.9 (455)	STD/TSU 18.8 (477)	STD/TSU 18.7 (475)
63.8 (1620)	63.8 (1620)	66.9 (1700)	66.9 (1700)
8088 (3669)	8838 (4009)	9786 (4439)	11,014 (4996)
10885 / 1203 (4937 / 546)	12,386 / 1452 (5618 / 659)	14,213 / 1573 (6447 / 713)	15,759 / 2255 (7163 / 1025)
4258 / 3830 (1931 / 1737)	4101 / 4737 (1860 / 2149)	4271 / 5515 (1937 / 2502)	4292 / 6722 (1947 / 3049)
Pneumatic	Pneumatic	Pneumatic	Pneumatic
7.00x12 - 14PR	7.00x12 - 14PR	8.15x15 - 14PR	250x15-18PR
6.00x9 - 10PR	6.00x9 - 10PR	6.50x10 - 12PR	6.50x10-12PR
2 x / 2	2 x / 2	2 x / 2	2 x / 2
39.1 (994)	39.1 (994)	40.5 (1028)	41.3 (1050)
35.6 (904)	35.6 (904)	35.9 (912)	35.9 (912)
5B / 6F	5B / 6F	5B / 6F	5B/6F
STD 85.2 (2165)   TSU 85.2 (2165)	STD 85.2 (2165)   TSU 85.2 (2165)	STD 85.8 (2180)   TSU 85.8 (2180)	STD 87 (2200)   TSU 87.0 (2200)
STD 4.1 (104)   TSU 59.2 (1511)	STD 4.1 (104)   TSU 59.2 (1511)	STD 4.3 (109)   TSU 57.7 (1466)	STD 4.5 (114)   TSU 57.0 (1448)
STD 130 (3302)   TSU 189 (4800)	STD 130 (3302)   TSU 189 (4800)	STD 130 (3302)   TSU 189 (4800)	STD 125 (3175)   TSU 182 (4620)
STD 178 (4521)   TSU 237 (6020)	STD 178 (4521)   TSU 237 (6020)	STD 178 (4521)   TSU 237 (6020)	STD 173 (4394)   TSU 230 (5842)
85.2 (2165)	85.2 (2165)	85.8 (2180)	86.4(2195)
44.7 (1135)	44.7 (1135)	45.3 (1151)	45.7 (1161)
16.0 (406)	16.0 (406)	16.0 (406)	16.0 (406)
STD/TSU 140.3 (3564)	STD/TSU 142.7 (3625)	STD/TSU 147.0 (3734)	STD/TSU 151.0 (3835)
STD/TSU 98.3 (2496)	STD/TSU 100.7 (2558)	STD/TSU 105.0 (2668)	STD/TSU 109.0 (2770)
48.2 (1225)	48.2 (1225)	48.7 (1237)	51.8 (1315)
1.75x4x42 (45x100x1070)	1.75x4x42 (45x100x1070)	1.75x4.8x42 (45x122x1070)	2.0x4.8x42 (50x122x1070)
Hook Type	Hook Type	Hook Type	Hook Type
41.0 (1041)	41.0 (1041)	41.0 (1041)	45.0 (1143)
5.3 (135)	5.3 (135)	5.9 (150)	6.5 (165)
6.1 (155)	6.1 (155)	6.5 (165)	6.5 (165)
STD/TSU 106.3 (2700)	STD/TSU 108.5 (2755)	STD/TSU 113.5 (2882)	STD/TSU 116.3 (2955)
88.4 (2245)	90.6 (2300)	94.7 (2405)	97.6 (2480)
11.5 (291)	11.5 (291)	11.3 (287)	11.3 (287)
12.0/12.7 (19.3/20.4)	12.0/12.7 (19.3/20.4)	12.7/13.3 (20.5/21.4)	13.0/13.4 (21.0/21.5)
STD 110/128 (.56/.65)   TSU 106/124 (.54/.63)	STD 108/128 (.55/.65)   TSU 104/124 (.53/.63)	STD 106/128 (.54/.65)   TSU 102/124 (.52/.63)	STD 94.5/124 (.48/.63)   TSU 90.6/120 (.46/.61)
STD 89/89 (.45/.45)   TSU 85/85 (.43/.43)	STD 89/89 (.45/.45)   TSU 85/85 (.43/.43)	STD 89/89 (.45/.45)   TSU 85/85 (.43/.43)	STD 89/89 (.45/.45)   TSU 85/85 (.43/.43)
5209 / 23,170	5348 / 23,790	4640/ 20,640	4634 / 20,613
46.2 / 27.1	40.4 / 23.8	29.1 / 22.9	25.8 / 17.4
Drum	Drum	Drum	Drum
Yanmar 4TNV94	Yanmar 4TNV94	Yanmar 4TNV94	Yanmar 4TNV94
59 / 42.9 @ 2500	59 / 42.9 @ 2500	59 / 42.9 @ 2500	59 / 42.9 @ 2500
2650	2650	2650	2650
4 / 171 - 2.8	4 / 171 - 2.8	4 / 171 - 2.8	4 / 171 - 2.8
Adjustable	Adjustable	Adjustable	Adjustable
79	79	79	79

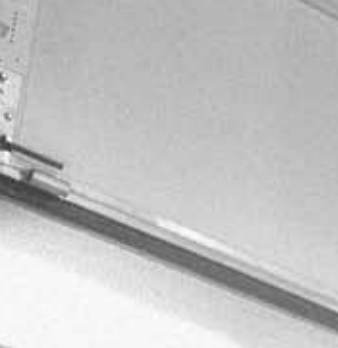

## ***& Don't Forget...*** **Safety Starts With You!**

**Before operating a lift truck, an operator must:**

- Be trained and authorized
- Read and understand operator's manual
- Not operate a faulty lift truck
- Not repair a lift truck unless trained and authorized
- Have the overhead guard and load backrest extension in place
- Perform daily inspections

**During operation, a lift truck operator must:**

- Wear a seat belt
- Keep entire body inside truck cab
- Never carry passengers or lift people
- Keep truck away from people and obstructions
- Travel with lift mechanism as low as possible and tilted back
- Allow safe stopping distance and come to a complete stop before leaving operator compartment

**To park a lift truck, an operator must:**

- Completely lower forks or attachments
- Shift into neutral
- Turn key off
- Set parking brake



- We don't just build forklifts. As a company, we are also focused on providing our customers with the best possible technical service support and aftermarket parts available.
- Even though our business starts with a quality, cost-effective product, our organization understands that it is the support and services we provide after the sale that help keep your business running at peak efficiency.
- **THE CLARK PartsPRO® SYSTEM** is our industry-leading electronic parts and service documentation tool that provides dealers with a quick and accurate method of identifying parts for every CLARK forklift built since 1961. PartsPRO® ensures the availability of the most current technical information and has the unique capability to create parts manuals specific to your mixed CLARK fleet, making it simple to positively identify and order the correct part(s) from your local CLARK dealer. The right CLARK part — The First Time, Every Time.
- **UNRIVALED PARTS SUPPORT** Our Aftermarket Distribution Center provides parts to over 250 North American CLARK dealers and many international dealers. This CLARK operated 184,000 square foot facility is dedicated to supporting the CLARK models built over the last 90 years. This facility is focused on providing excellent off-the-shelf availability, quality parts, quick response time and competitive pricing.

**DEPENDABLE PARTS = DEPENDABLE TRUCKS**

To Find Your Nearest Authorized CLARK Dealer, Visit Our Website [www.clarkmhc.com](http://www.clarkmhc.com)



**BUILT TO LAST.®**



**CLARK MATERIAL HANDLING COMPANY**

North American Headquarters  
700 Enterprise Drive • Lexington, KY 40510  
866-252-5275 • [www.clarkmhc.com](http://www.clarkmhc.com)

**C20/25/30/32C & C20/25/30/35**  
59-894-0335 Printed in USA CR030810M

© 2008 CLARK Material Handling Company